

# Authority Data

International Workshop:  
MARC 21 – Experiences,  
Challenges and Visions

Deutsche Nationalbibliothek  
14-15 May 2007  
Glenn Patton

# Topics

---

- Authority Data in MARC 21
- The FRAD Model
- FRBR, FRAD and MARC 21
- Questions

## MARC 21 Authority records contain

- coded data that describes characteristics of the record (008 elements)
- established form of the heading (1xx tags)
- *see from* references (4xx tags)
- *see also from* references (5xx tags)
- notes (6xx tags)
- linking headings (7xx tags)

# Mapping fields

## Bibliographic

## Authority

100, 600, 700

100

130, 630, 730, 830

130

110, 610, 710

110

111, 611, 711

111

1xx/240

1xx/\$t

440, 490

130

6xx,7xx/810/\$t

1xx/\$t

# Authorities: Field 008

- 00-05 - Date entered on file
- 06 - Direct or indirect geographic subdivision
- 07 - Romanization scheme
- 08 - Language of catalog
- 09 - Kind of record
- 10 - Descriptive cataloging rules
- 11 - Subject heading system/thesaurus
- 12 - Type of series
- 13 - Numbered or unnumbered series
- **14 - Heading use--main or added entry**
- **15 - Heading use--subject added entry**
- **16 - Heading use--series added entry**
- 17 - Type of subject subdivision
- 18-27 - Undefined character positions
- 28 - Type of government agency
- 29 - Reference evaluation
- 30 - Undefined character position
- 31 - Record update in process
- **32 - Undifferentiated personal name**
- 33 - Level of establishment
- 34-37 - Undefined character positions
- 38 - Modified record
- **39 - Cataloging source**

# Authorities: Variable Fields

- **001 – Control number**
- **020 – ISBN**
- **022 – ISSN**
- **024 – Other standard identifiers**
- **040 – Cataloging source**
- **043 – Geographic area code**
- **045 – Time period of heading**
- **050-099 Classification numbers**

# Authorities: Variable Fields

- **1XX**            **Established headings**
- **260**            **Complex see reference (subject)**
- **360**            **Complex see *also* reference  
(subject)**
- **4XX**            ***See from* reference**
- **5XX**            ***See also from* reference**
- **6xx**            **Various types of notes fields**
- **7xx**            **Linking fields**

# 1xx: Heading fields

- **Fields 100-185 contain names, uniform titles, and terms used in headings or subdivisions to headings. They are usually constructed according to generally accepted cataloging and thesaurus-building rules.**
- **In a MARC authority record, a heading is the content of a 1XX, 4XX, or 5XX field that documents the form of name, title, or term used for indexing and retrieval or organizational purposes in a file.**
- **The content designation of the subelements of each type of heading is consistent across the 1XX heading and 4XX/5XX tracing fields.**

# 1xx: Heading fields

- 100 Personal name
- 110 Corporate name
- 111 Meeting name
- 130 Uniform title
- 148 Chronological term
- 150 Topical term
- 151 Geographic name
- 155 Genre/form term
- 180 General subdivision
- 181 Geographic subdivision
- 182 Chronological subdivision
- 185 Form subdivision

# Content designation for field 100

- \$a - Personal name (NR)
- \$b - Numeration (NR)
- \$c - Titles and other words associated with a name (R)
- \$d - Dates associated with a name (NR)
- \$e - Relator term (R)
- \$f - Date of a work (NR)
- \$g - Miscellaneous information (NR)
- \$h - Medium (NR)
- \$j - Attribution qualifier (R)
- \$k - Form subheading (R)
- \$l - Language of a work (NR)
- \$m - Medium of performance for music (R)
- \$n - Number of part/section of a work (R)
- \$o - Arranged statement for music (NR)
- \$p - Name of part/section of a work (R)
- \$q - Fuller form of name (NR)
- \$r - Key for music (NR)
- \$s - Version (NR)
- \$t - Title of a work (NR)
- \$v - Form subdivision (R)
- \$x - General subdivision (R)
- \$y - Chronological subdivision (R)
- \$z - Geographic subdivision (R)
- \$6 - Linkage (NR)
- \$8 - Field link and sequence number (R)

## 4XX: *See from* Tracing fields

Fields 400-485 fields are used to identify unauthorized forms of headings and other variants not chosen as an authorized form.

- Some 4xx fields are present based on cataloging rules.
- Some 4xx fields are present to show relationships with previously established headings.
  - \$w nna
    - 400 1 Callaghan, Bede Bertrand, \$c Sir, \$d 1912- \$w nna
  - \$w nne
    - 450 Hotels, taverns, etc. \$w nne

## 5XX: *See also from* Tracing fields

**Fields 500-585 fields are used to identify different authorized forms of headings related to the authorized form of heading in the 1XX field.**

- Some 5xx fields show relationships with later headings,
  - 110 2 OCLC
  - 510 2 Ohio College Library Center \$w a
- Some 5xx fields show relationships with other valid forms of names (e.g., pseudonyms)
  - 500 1 Clemens, Samuel Langhorne, \$d 1835-1910 \$w nnnc
- Some 5xx fields show relationships with broader terms,
  - 150 Dogs
  - 550 Domestic animals \$w g

## **6XX:**

- **640-646: Series Treatment Fields**
- **663-666: Complex Name Reference Fields**
- **667-68x: Note Fields**

## **6xx: Note fields**

- **667 – Nonpublic general note**
- **670 – Source data found**
- **675 – Source data not found**
- **678 – Biographical or historical data**
- **680 – Public general note**
- **681 – Subject example tracing note**
- **682 – Deleted heading information**
- **688 – Application history note**

# 667: Nonpublic general note

**General information about a 1XX heading for which a specialized note field has not been defined.**

**667 Formerly on undifferentiated name record: n88-620080**

**667 DESCRIPTIVE USAGE: NOT VALID AS A CORPORATE NAME  
HEADING. "Society of Friends" is a religious group, not a denomination; not valid for main or added entry or for entry element in corporate name references. "(Society of Friends)" is valid as qualifier for Society of Friends "Meetings" that lack the term "Friends." ("Meetings" are entered directly under their own names.)**

**667 SUBJECT USAGE: As a geographic subdivision, this heading is used indirectly through Malaysia.**

**667 Further subdivide by subdivisions used under legal topics.**

## 670: Source data found

A citation for a consulted source in which information is found about the 1XX heading in an established heading record, an established heading and subdivision record, a subdivision record or a reference record. The information found in the source may also be present.

670 New Grove ÷b (under Mozart: (Johann Chrysostom) Wolfgang Amadeus Mozart; b. Jan. 27, 1756, Salzburg, d. Dec. 5, 1791, Vienna; Austrian composer)

670 Washington post, 4/9/85 ÷b (Stephen King has written 5 novels using the pseudonym Richard Bachman)

# 680: Public general note

General information about a 1XX heading for which a specialized note field has not been defined. The note is written in a form adequate for public display.

**680**      \$i Here are entered musical compositions. Works about the waltz as a dance are entered under the heading |a Waltz.

**680**      ≠i Use as a topical subdivision under individual animals and groups of animals, individual chemicals, individual diseases, types of educational institutions, types of industries, individual materials, individual plants and groups of plants, individual land vehicles, and individual wars.

# The FRAD Model

**Draft currently available for review at:**

**<http://www.ifla.org/VII/d4/wg-franar.htm>**

**Comments due: 15 July 2007**

**Bibliographic  
Entities**

known by

**Names and/or  
Identifiers**

basis for

**Controlled Access  
Points**

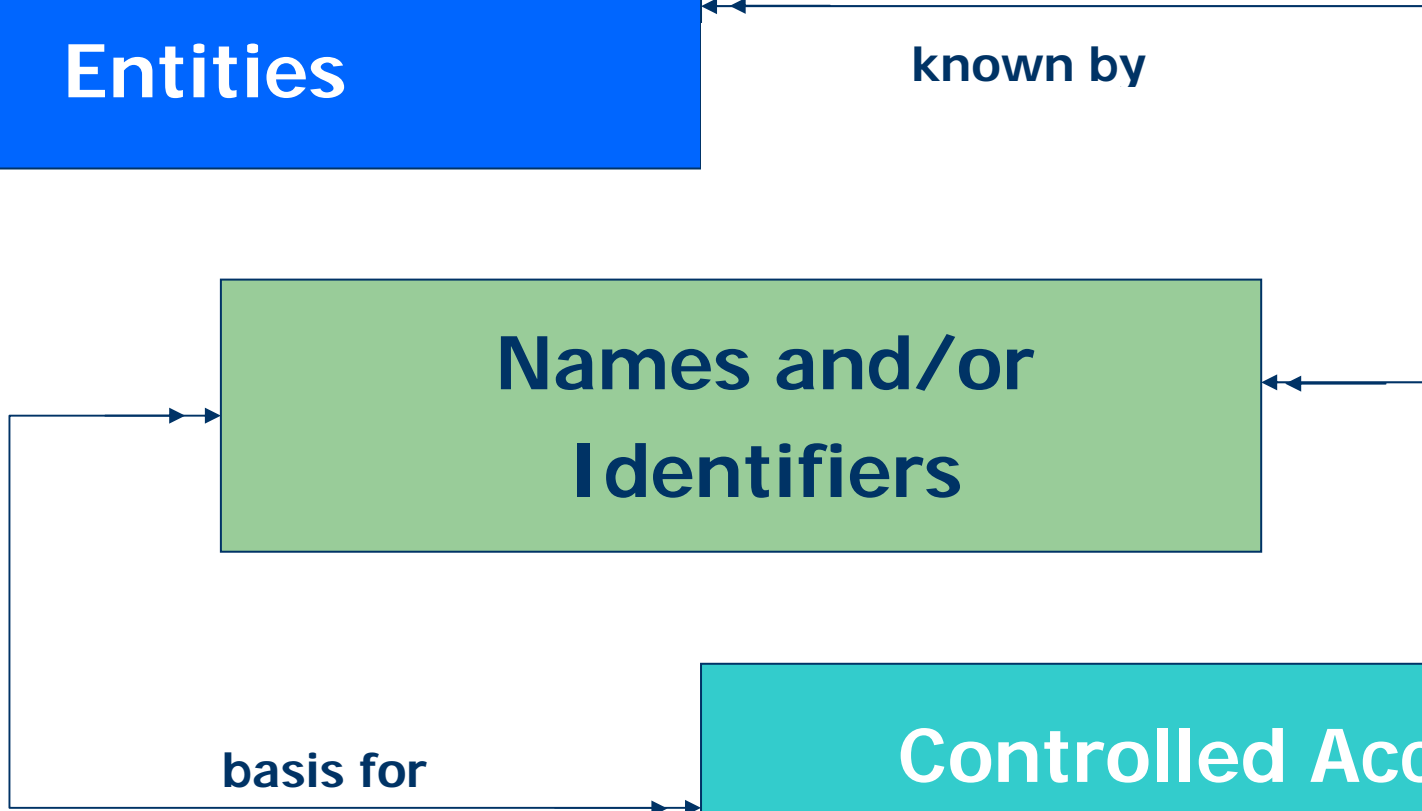

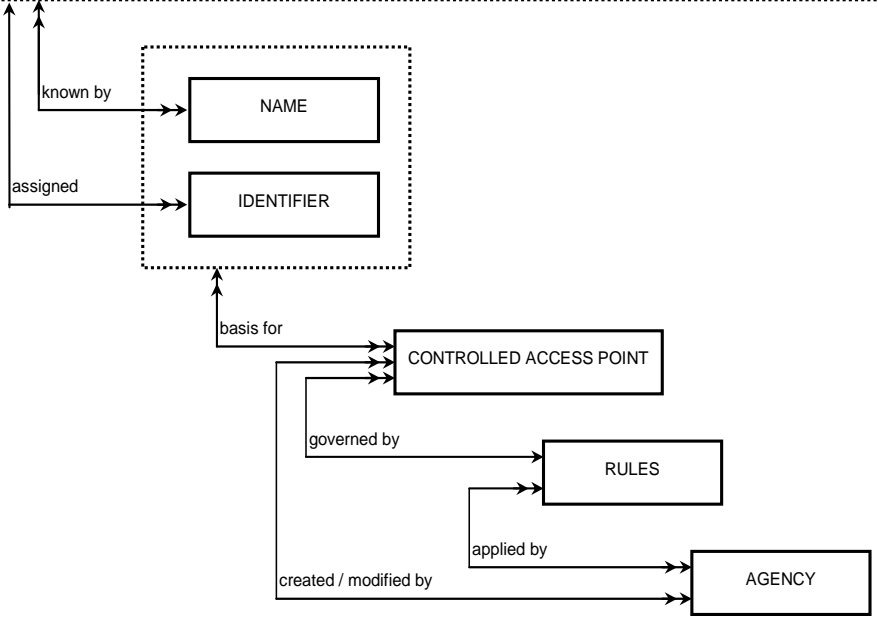
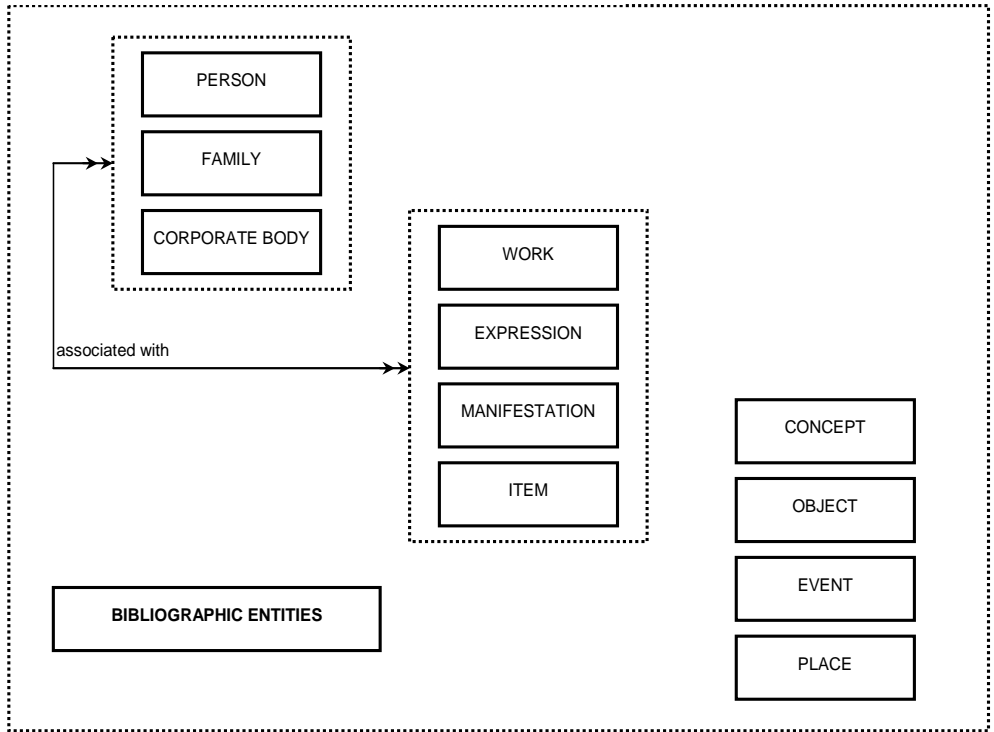

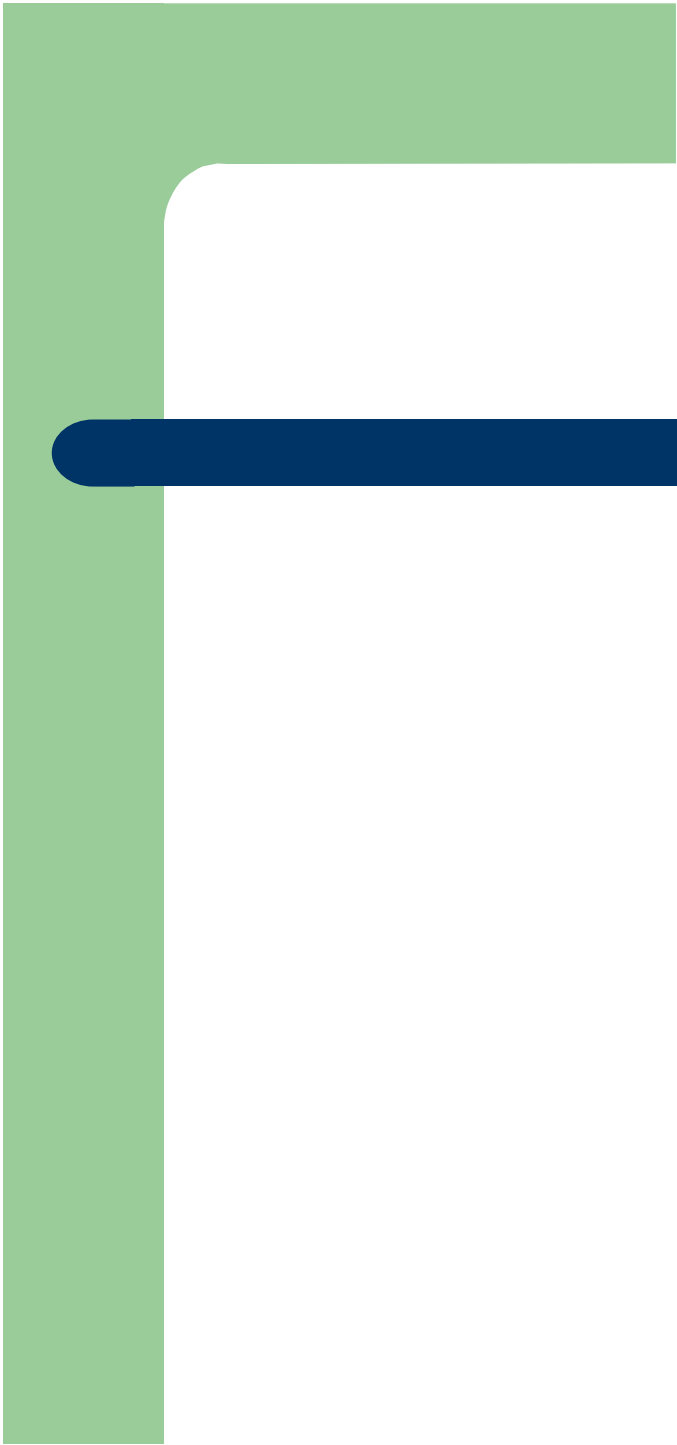

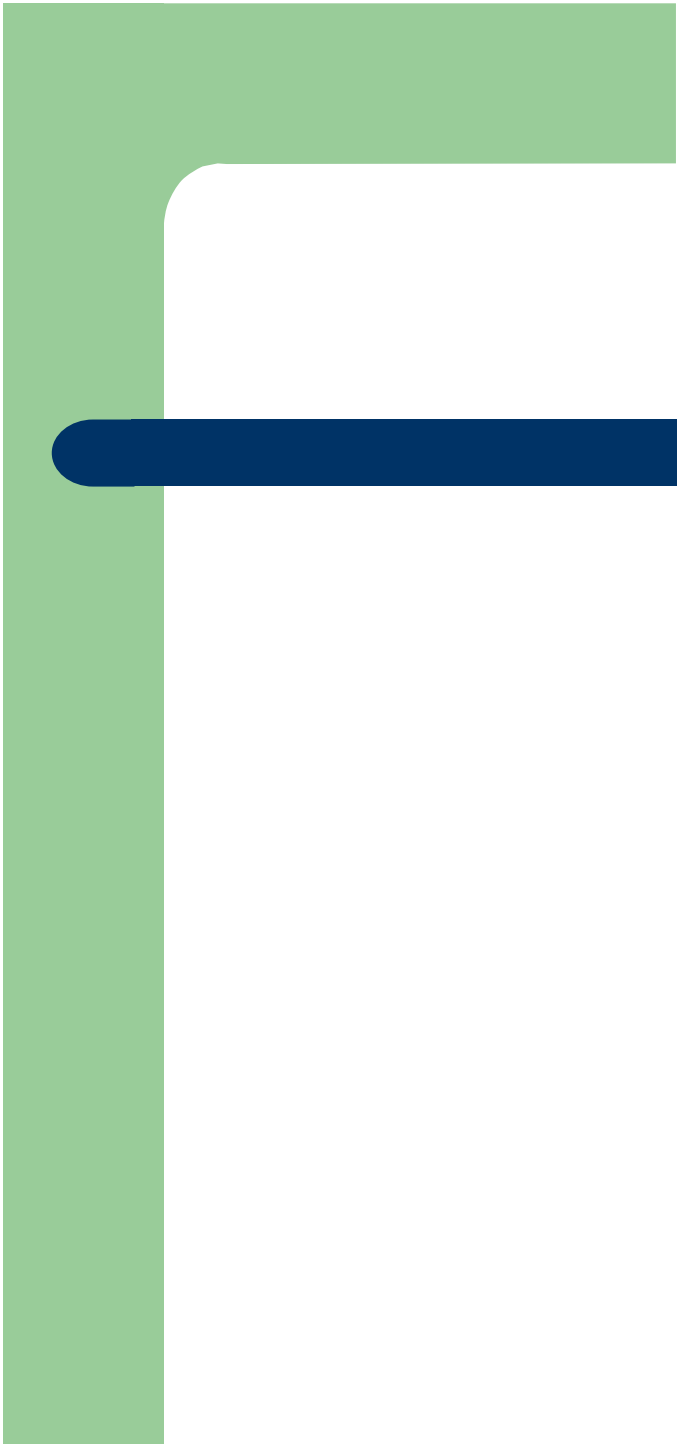



# Entities & attributes (1)

- Person

- An individual or a persona established or adopted by an individual or group

[FRBR, modified]

- *Dates of a person*
- *Title of person*
- *Place of birth*
- *Language of person*
- *Field of activity*
- *Affiliation*
- *Profession*
- [etc.]*

# Entities & attributes (2)

- Name

- A character or group of words and/or characters by which an entity is known

[FRBR, modified]

- *Type of name*
- *Scope of usage*
- *Dates of usage*
- *Language of name*
- *Script of name*
- *Transliteration scheme of name*
- [etc.]*

# Entities & attributes (3)

- Controlled access point

- A name, term, code, etc. under which bibliographic or authority record or reference will be found.

[GARR, modified]

- *Type of access point*
- *Language of cataloguing*
- *Script of cataloguing*
- *Source of access point*  
*[etc.]*

# Relationships (1)

Work  $\Rightarrow$  Work

- Successor relationship
  - Adaptation relationship
  - Transformation relationship
  - Whole/part relationship
- [etc.]

# Relationships (1)

Work ⇔ Work

- Transformation relationship

*Authorized heading:*

Poe, Edgar Allan, 1809-1849.

[Fall of the house of Usher]

*See also reference:*

For a musical composition based on this work search under:

>> Debussy, Claude, 1862-1918. Chute de la maison Usher

## Relationships (2)

### Person ⇔ Name

- Real name relationship
- Pseudonym relationship
- Married name relationship
- Secular name relationship  
[etc.]

## Relationships (2)

Person ⇔ Name

- Secular name relationship

*Authorized heading:*

John XXIII, Pope

*See reference tracing:*

< Roncalli, Angelo Giuseppe [secular name]

## Relationships (3)

Access point  $\Leftrightarrow$  Access point

- Parallel language relationship
- Alternate script relationship
- Different rules relationship

## Relationships (3)

Access point  $\Leftrightarrow$  Access point  
– Alternate script relationship

*Access point:*

Gogol, Nikolai Vasilievitch

*Access point in an alternate script:*

Гоголь, Николай Васильевич

# FRBR, FRAD and MARC 21



# Attributes in MARC 21 (1)

- **Person**

- |                             |                  |
|-----------------------------|------------------|
| ➤ <i>Dates of a person</i>  | <b>X00, \$d</b>  |
| ➤ <i>Title of person</i>    | <b>X00, \$c</b>  |
| ➤ <i>Place of birth</i>     | <b>670? 678?</b> |
| ➤ <i>Language of person</i> | <b>???</b>       |
| ➤ <i>Field of activity</i>  | <b>670? 678?</b> |

# Attributes in MARC 21 (2)

- **Name**

- |   |                            |
|---|----------------------------|
| ➤ <i>Type of name</i>                   | <b>X00, X10, X11, etc.</b> |
| ➤ <i>Scope of usage</i>                 | <b>667 or 680</b>          |
| ➤ <i>Dates of usage</i>                 | <b>678</b>                 |
| ➤ <i>Language of name</i>               | <b>???</b>                 |
| ➤ <i>Script of name</i>                 | <b>???</b>                 |
| ➤ <i>Transliteration scheme of name</i> | <b>???</b>                 |

# Attributes and MARC 21 (3)

- **Controlled access point**

- |                                  |                            |
|----------------------------------|----------------------------|
| ➤ <i>Type of access point</i>    | <b>100, 410, 530, etc.</b> |
| ➤ <i>Language of cataloguing</i> | <b>???</b>                 |
| ➤ <i>Script of cataloguing</i>   | <b>???</b>                 |
| ➤ <i>Source of access point</i>  | <b>670</b>                 |

# Relationships (1)

Work ⇒ Work

- Transformation relationship

100 1 Debussy, Claude, \$d 1862-1918. \$t Chute de la maison Usher

500 1 Poe, Edgar Allan, \$d 1809-1849. \$t Fall of the house of Usher \$w f

## Relationships (2)

Person ⇨ Name

- Secular name relationship

100 0 John \$b XXIII, \$c Pope, \$d 1881-1963

400 1 Roncalli, Angelo Giuseppe, \$c Cardinal, \$d 1881-1963

## Relationships (3)

Access point  $\Rightarrow$  Access point  
– Alternate script relationship

100 1 Gogol, Nikolai Vasilievitch

400 1 Гоголь, Николай Васильевич

*or*

700 17 Гоголь, Николай Васильевич \$2 [code]

# Future considerations

- Full analysis of what attributes MAY need to be recorded in a MARC 21 authority record
- Exploration of what a “work” or “work/expression” record might look like — is it an expanded authority record?



# Questions & Comments